



Owners Manual

J Series Decorative Aerators



Contents

Important Safety Instructions. . . .	pg2
General Owner's Instructions. . . .	pg2
Unit Specs. . . .	pg3
Parts Included. . . .	pg4
Assembly Instructions. . . .	pg5
Nozzle Options & Pattern Sizes. . . .	pg7
Optional Premium Nozzles. . . .	pg9
Installation Instructions. . . .	pg9
Control Panel Installation. . . .	pg10
C-85 Control Instructions. . . .	pg11
C-95 Control Instructions. . . .	pg12
3 Phase Startup Procedure. . . .	pg13
3 Phase Control Panel Timer. . . .	pg14
8400JF, 2.3JF Replacement Parts. . . .	pg15
3.1JF, 3.3JF Replacement Parts. . . .	pg16
5.1JF, 5.3JF Replacement Parts. . . .	pg17
7.3JF Replacement Parts. . . .	pg18
Maintenance Recommendations. . . .	pg19
Warranty Policy. . . .	pg20
Troubleshooting Tips. . . .	pg21
Customer Repair Form. . . .	pg22
Registration Information. . . .	pg24



3020379
ANSI/UL 778, 4th Ed. 2006
CAN/CSA C22.2 No. 108-M89
UL 50, 11th Ed. 1995

Kasco Marine, Inc.
800 Deere Rd.
Prescott, WI 54021
PH (715) 262-4488
FAX (715) 262-4487
www.kascomarine.com

THANKS

We at Kasco Marine, Inc. would like to both thank and congratulate you on your purchase of the JF model decorative aerator. We appreciate you choosing Kasco and for your purchase. Your decision to purchase Kasco's Decorative Aerator will not disappoint you. The JF Series Decorative aerator will be a great addition to your body of water. It will help improve the water quality by adding much needed oxygen and circulation. It will also enhance the aesthetics of the pond or lake with beautiful patterns. The lighting package (if purchased) will illuminate your aerator for beauty day and night. We thank you for choosing Kasco for your aerator needs and want you to be completely satisfied with your purchase.

Important Safety Instructions

Please read and follow these extremely important safety and handling instructions for your Kasco equipment. Following these instructions will help ensure your safety and the quality performance of your equipment.

- Under NO circumstances should anyone enter the water with the electrical equipment plugged in and/or in operation. All Kasco equipment is ETL approved to UL and CSA standards for safety in water. However, it is NEVER recommended to enter the water with the equipment in operation.
- Caution should be used when dealing with any electrical and/or moving equipment.
- NEVER run the unit out of water. It will damage the seals and create a dangerous situation for the operator.
- Extreme caution should be used around water, especially cold water, such as in Spring, Fall, and Winter. Cold water poses a hazard in and of itself.
- NEVER lift or drag the aerator by the power or light cord. If you need to pull the unit to the side of the pond, use the anchoring ropes.
- Do not use waders in deep ponds/lakes or ponds/lakes with drop-offs, drastic slopes, or soft bottom material.
- Do not use boats that tip easily for aerator installation, such as a canoe, and follow all boating safety rules and regulations, including wearing a PFD (Personal Flotation Device).
- Single phase aerators (8400, 3.1, and 5.1JF) are

supplied with an internal grounding conductor and/or a grounding-type attachment plug. To reduce the risk of electrical shock, be certain the aerator is properly connected to the Kasco supplied control panel. (refer to the C-85 & C-95 Control instruction)

- 3 phase aerators (2.3, 3.3, 5.3, 7.3JF) require a startup test after wiring to ensure proper rotation of the impeller. If the impeller is rotating in the opposite direction, the unit will not perform properly and internal damage to the unit may occur. (See 3 phase startup procedure)
- Control panels must be installed a minimum of 5ft(3m in Canada) from the inside wall of the pond, unless separated from the body of water by a fence wall, or other permanent barrier that will make the unit inaccessible to persons in the water.
- Control panels must be installed by a qualified electrician.
- Ground Fault Circuit Interrupters (GFCI) should be tested upon each installation and every month thereafter to ensure proper operation.

General Owner's Instructions

INSPECT THE SHIPMENT

Immediately inspect your Kasco aerator shipment for any visible damages. Also cross reference the parts supplied with the Parts Included sheet to check for shortages. Shortages should be reported immediately to your Kasco Marine distributor or representative and damages reported to your carrier and Kasco Marine.

CAUTION

WARNING: Under NO circumstances should anyone enter the water with the unit in operation. Always operate the unit in the water and keep people and objects clear of the propeller. Do not lift or pull the unit by the electrical cord. Always use extreme caution around electrical equipment and water situations.

ASSEMBLY & INSTALLATION

Please see the proper Assembly and Installation Instructions enclosed in this manual. Each is specific for your model and size of aerator. Note: Use a nylon tie to help keep the power cords for the unit and lights free of the impeller by tying each cord to either side of the float. If you have a light kit, make sure that the unit cord is tied to one side of the float and the light cord to

the other for balance. Note: It is extremely important to test the GFCI in the control panel upon each installation/reinstallation of the unit to ensure proper functioning.

USE AND OPERATION

Kasco Aerators are designed and engineered for continuous duty, such as on fish farms or other aquaculture applications, or on-demand use, as needed in a recreational water feature.

During flotation operation, the water is pulled from 360° around the unit and from below the unit. The water is pulled upward and thrust through the flotation collar into the air.

Your Kasco Marine aerator is ready for immediate use (after installation). Make sure to keep the motor housing clean from hard water deposits and/or algae. (See Maintenance Recommendations)

It is extremely important that proper and sufficient voltage is supplied to the aerator motor. Unit should be protected by a GFCI. Control panels must be installed by a qualified electrician. (See Installation instructions).

Kasco aerators are lightweight, energy efficient, and easy to install and operate. We strive to produce products that exceed customer expectations. We hope you enjoy your Kasco aerator.

Unit Specs

<i>Single Phase 208-240 Volt</i>	8400JF	3.1JF	5.1JF
Voltage	208-240	208-240	208-240
Amps	10.5	13.4	20
Lock rotor amps	40	61	97
Control box connection	C-85 Hardwire at shore	C-85 Hardwire at shore	C-95 Hardwire at shore
Aerator connection	plug or hardwire into C-85	plug or hardwire into C-85	hardwire into C-95

<i>3 phase 208- 230 Volt</i>	2.3JF	3.3JF	5.3JF	7.3JF
Voltage	208	208	208	208
Amps @208V	7.5	10.3	16.0	20.0
Lock rotor amps	40	70	100	100

<i>3 phase 460 Volt</i>	2.3HJF	3.3HJF	5.3HJF	7.3HJF
Voltage	460	460	460	460
Amps	3.6	5.1	7.8	10.0
Lock rotor amps	24	40	49	50

Parts Included

- 8400JF, 3.1JF, or 5.1JF Aerator
 2.3JF, 3.3JF, or 5.3JF Aerator
 (Unit with cord or unit with Disconnect) (1)
 A1. Cord in separate box (1) (depending on size of cord)
 B. Float in separate box (1) (Diagram)
1. 3 Float Sections (1)
 2. Top Float Bracket (3)
 3. Bottom Float Bracket w/ 50' rope (3)
 4. 9" x 3/8" Black Coated Bolt (6)
 5. 3/8" Lock Nut (9)
 6. Unit Mounting Bracket (3) (not with 7.3)
 7. 1/4" x 3/4" Bolt (6)
 8. 1/4" Lock Washer (9)
 9. Bottom Screen (1)
 10. Top Screen (1)
 11. Top Screen Clip (3)
 12. 1/4-20 x 3/4" Brass Screw (3)
 13. 1/4 nut (3)
 14. Bottom Screen Clip (3)
 15. 3/8-16 x 1" Bolt (3)
 16. 3/8 lock washer (3) (7.3 only)

8400JF, 3.1JF, 2.3JF, 3.3JF parts diagram

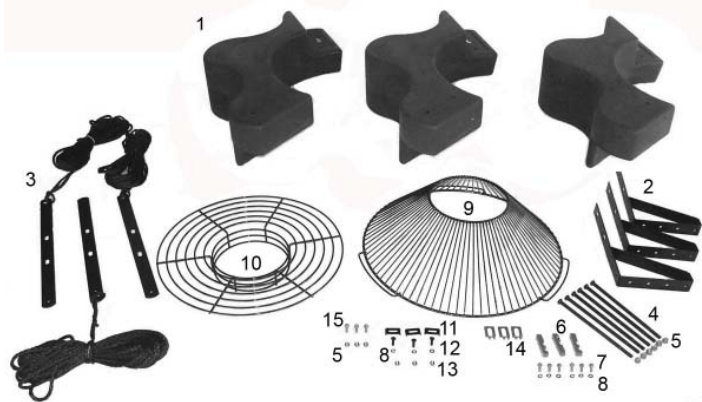

5.1JF, 5.3JF, 7.3JF parts diagram

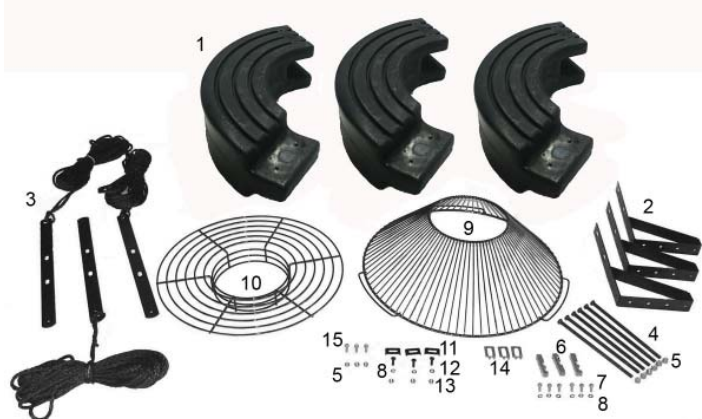

Control Panel in separate box (1) (if purchased)

Set of Interchangeable Nozzles (5) (Diagrams)

1. #6 x 1/2" Ph Pan Head Self Tap Screw (3)
2. 3/8" x 4" bolt (1)
3. Linden Nozzle (1)
4. Redwood Y Insert (installed in #7)(1)
5. Juniper Nozzle (1)
6. Willow Nozzle (1)
7. Redwood & Spruce Nozzle (1)
8. Sequoia Nozzle
9. 3/8" x 2.5" Bolt (1)

8400JF, 3.1JF, 2.3JF, 3.3JF Nozzle Diagram



5.1JF, 5.3JF Nozzle Diagram



7.3JF Nozzles include linden and sequoia.

NOTE: Extra hardware may be included.

Tools & Supplies Needed

- Anchors or stakes for installing unit (3)
- Philips head screw driver for mounting C-85
- Electrical Supply near pond on a post with room for mounting the control panel
- Three 12" galvanized pipe for weighting ropes (optional)
- #10 x 1" long or longer screw(s) for mounting the control panel (4)
- 7/16" Socket & Wrench (1)
- 7/16" Wrench (1)
- 9/16" Socket & Wrench (1)
- 9/16" Wrench or adjustable crescent wrench (1)
- Flat head screw driver (1)

Assembly Instructions

STEP ONE

Remove all contents from package and place on a clean, flat surface. Inspect the shipment for any damages. If damages are found, immediately notify your carrier and your Kasco Marine, Inc. representative. Next, cross reference the parts included in the shipment with the Parts Included sheet in this manual. Make sure you have all the parts needed. If any shortages are found, contact your Kasco representative immediately.

STEP TWO

Arrange the three Float Sections (Part #B1) upright (plug on bottom) so the overlap of one section aligns with the next section and loosely push the three sections together to form a continuous ring.

8400JF, 3.1JF, 2.3JF, 3.3JF

Float up

Float down
(plug)



5.1JF, 5.3JF, 7.3JF



STEP THREE

Position one Top Float Bracket (Part #B2) so that the bolt holes in the bracket align with the bolt holes in the two adjoining float sections and insert two 9" Coated

Bolts (Part #B4) through the assembly. This may require some minor repositioning of the float sections as you push the bolt all the way through. Do not force the bolt through. Repeat for the remaining two joints.



STEP FOUR

Turn the assembly upside down and place the Bottom Float Brackets (Part #B3) over the bolts, the ends of which should now be extending through the assembly. Loosely install the six 3/8" Lock Nuts (Part #B5) on the ends of the bolts (do not tighten yet).



(for 8400, 2.3, 3.1, 3.3, 5.1, 5.3)

Connect the Top and Bottom Float Brackets using three 3/8" x 1" Bolts (Part #B15) with three 3/8" lock nuts (Part #B5) and tighten using the 9/16" wrench and socket.

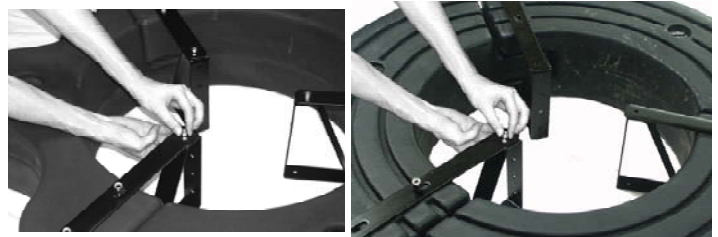

STEP FIVE (for 8400, 2.3, 3.1, 3.3, 5.1, 5.3)

Place the motor assembly (Stainless Steel can side up, black pump down) in the center of the float. Attach the motor to the float using the Unit Mounting Brackets (Part #B6).

For 8400, 3.1, 2.3, 3.3 Units, the notch in the center of the Unit Mounting Brackets should be positioned over the top ring of the cage and should be attached to the float bracket using the two middle holes of the float bracket.

For 5.1JF, 5.3JF, the lower notch of the Unit Mounting Bracket should be positioned over the top ring of

the cage and should be attached to the Float Bracket using the two lowest holes (closest to the Lower Bracket) of the Top Float Bracket.

Tighten using the 1/4" x 3/4" Bolts with 1/4" Lock Washers using the 7/16" socket and wrench. Note: If you have trouble positioning the Unit Mounting Bracket between the Cage and Aerator Housing, you can use a screwdriver to gently pry open enough space.

8400JF, 3.1JF, 2.3JF, 3.3JF

5.1JF, 5.3JF



STEP FIVE (for 7.3)

Rest the float on the base plate of the unit. Connect the float to the base plate using the 3/8" x 1" bolt (Part #B15) and 3/8" lock washer (Part #B16). Tighten using a 9/16" wrench.



STEP SIX

Center the Top Screen (Part #B10) inside the three Top Float Brackets. Attach the screen by spanning each Top Screen Clip (Part #B11) across the two innermost rings on the screen and the hole in the float bracket. Insert the 3/4" Brass Screws (Part #B12) and attach

with 1/4" Lock Washers and 1/4" Nuts (Part #B13) to secure the screen to the float assembly.



STEP SEVEN

Position the Bottom Screen (Part #B9) over the float so the motor housing (can) passes through the large hole in the center of the screen. Remove the center three 3/8" Lock Nuts from the 9" Bolts and place the Bottom Screen Clips (Part #B14) over the bolts as shown. The power cord can be slid under the bottom screen between the float and screen where two float sections come together before the 3/8" Lock Nuts are replaced. Replace the three inside Lock Nuts and tighten all 3/8" Lock Nuts using the 9/16" wrench and socket.

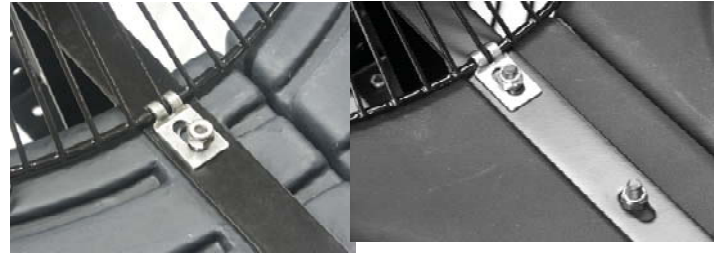

STEP EIGHT

Return the unit to its upright position and select a nozzle (See Nozzle and Pattern Options). Insert the Shaft Bolt (Part #D2) into the Nozzle Head so it fits snugly into the molded socket for those nozzles that use the bolt. Install the Nozzle by threading it into the inner cone of the pump. Make sure to tighten the Nozzle all the way down.



To install the Redwood nozzle, make sure the Y Insert (Part #D4) is installed and seated properly into the Nozzle Housing (Part #D7). Push the nozzle down over the cone assembly (it may require light taps with a rubber mallet to seat properly). Next, use the 3 Self Tapping Screws (Part #D1) provided in the 3 holes on the nozzle and tighten the screws into the cone assembly. Once you feel resistance, two more turns will be sufficient. To install the Spruce nozzle, follow the same steps, but do not install the Y Insert.



STEP NINE

On power cord lengths of 100 feet or longer with the watertight Quick Disconnect, the power cord is shipped separately. It should now be attached to the stub cord by lining up the male and female halves of the disconnect and hand tightening the blue collar. On these cords, the Additional Strain Relief should be attached to one of the lower float brackets as pictured. If you receive a 3 chain strain relief (6 or 8 gauge cord), attach one chain to each of the three lower float brackets. If there is not Strain Relief, use the Nylon Cable Tie provided to secure the cord to a rope to prevent damage by the propeller. Double check the Quick Disconnect to make sure the threaded collar has not come loose in shipping before placing in the water. If installing a new Quick Disconnect, please refer to Quick Disconnect instructions. Also, at this time, lights can be installed if purchased.



1 chain strain relief

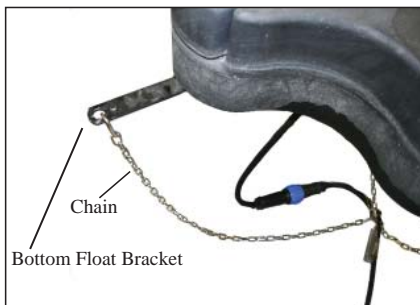

3 chain strain relief

Nozzle Options & Pattern Sizes

NOTE: Pattern sizes listed are approximate in feet. Variations in voltage caused by regional electrical differences or voltage drop due to long power cords may result in reduced pattern sizes.

- All five (or six) nozzles are included with the package.
- The Linden, Willow, and Juniper nozzles use the 3/8" x 4" bolt.
- The Sequoia (5.1JF only) uses the 3/8" x 2.5" bolt.
- The Redwood nozzle must have the Y Insert installed prior to nozzle placement.
- The Spruce nozzle must have the Insert removed prior to nozzle placement.
- The Birch display does not require a nozzle.

The **Redwood** nozzle uses the 3 self tapping screws to attach over the pump housing and the Y Insert must be installed.



Model	HP	Height	Width
8400, 2.3	2	22'	7'
3.1, 3.3	3	24'	8'
5.1, 5.3	5	26'	8'

The **Linden** nozzle (marked L inside one of the fins) uses the 3/8" x 4" bolt.



Model	HP	Height	Width
8400, 2.3	2	18'	30'
3.1, 3.3	3	19'	35'
5.1, 5.3	5	20'	35'
7.3	7.5	24'	28'

The **Willow** nozzle (marked W on the inside of the cone) uses the 3/8" x 4" bolt



Model	HP	Height	Width
8400, 2.3	2	12.5'	28'
3.1, 3.3	3	13'	35'
5.1, 5.3	5	14'	36'

The **Birch** display does not use a nozzle or bolt. It is the aerator unit running without any nozzle and allows for the best flow rate and oxygen transfer!



Model	HP	Height	Width
8400, 2.3	2	12'	11'
3.1, 3.3	3	14.5'	10'
5.1, 5.3	5	14'	12'
7.3	7.5	14.5'	13'

The **Juniper** nozzle (marked with J on in inside of the nozzle cone) uses the 3/8" x 4" bolt.



Model	HP	Height	Width
8400, 2.3	2	8'	46'
3.1, 3.3	3	9'	48'
5.1, 5.3	5	10'	50'

The **Sequoia** nozzle (marked S on the inside of the cone) uses the 3/8" x 2.5" bolt.

5.1JF, 5.3JF ONLY



Model	HP	Height	Width
5.1, 5.3	5	21'	10'
7.3	7.5	26'	10'

The **Spruce** nozzle uses the three self tapping screws to attach over the pump housing and the Y Insert must be removed.



Model	HP	Height	Width
8400, 2.3	2	19'	10'
3.1, 3.3	3	21'	13'
5.1, 5.3	5	24'	15'

Optional Premium Nozzles

The following are optional premium nozzles available for the J Series Decorative Aerators. Premium nozzles offer splendid beauty above and beyond our included patterns.

Madrone Premium Nozzle:



Magnolia Premium Nozzle:



Palm Premium Nozzle:



Mahogany Premium Nozzle:



Contact your authorized Kasco distributor or visit www.kascomarine.com for more information.

Installation Instructions

STEP TEN

Before installing 3 phase units (2.3, 3.3, 5.3, 7.3) into the pond, please refer to 3 phase startup procedure.

Use the ropes to position the aerator in the desired location in the pond/lake. Anchor the ropes or secure them to the shoreline so the ropes are free of slack, but not tight. To prevent twisting of the unit due to torque, you should place the anchor at least 3 feet from the float for each foot of depth (Ex. A 6 foot deep pond would require an anchor 18 feet horizontally from the float.)

For ease of removal, you may choose to keep at least one anchor within reach from shore, just below the water's surface.

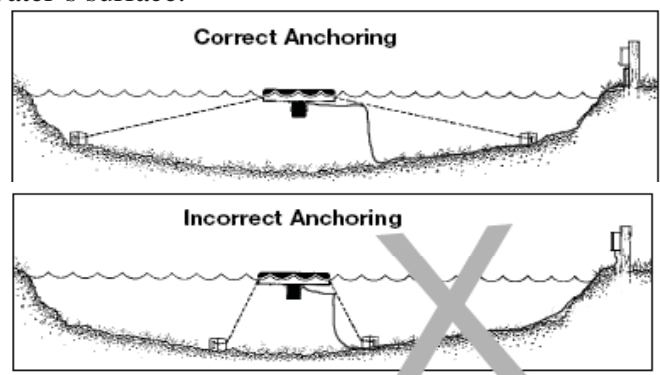

STEP ELEVEN (ALTERNATE INSTALLATION)

In ponds where the water level fluctuates significantly, you may need to suspend a small weight (12" of 1"

galvanize pipe works well) at the mid-point of the rope to take up any slack as the water level drops. The weight should be light enough so the aerator can rise as the water level rises. This can also help hide ropes by sinking them further below the surface.

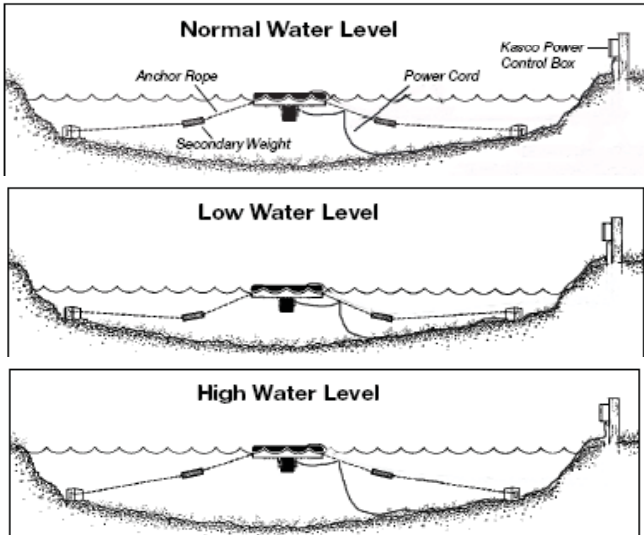

Control Panel Installation

STEP ONE

Install the control panel on the post with the power supply. Use #10 x 1" long or longer screws and the screw placements on the control panel to secure the panel to the post. NOTE: The control panel must be hung upright in order to be waterproof.

STEP TWO

Set Timer in the control panel to desired ON and OFF times per the Instructions on the door label or the label printed in this manual.

STEP THREE

Electrical Service wiring:

3 phase: (2.3, 3.3, 5.3, 7.3)

Refer to your 3 phase control panel instructions.

Single Phase: (8400, 3.1, 5.1)

To hardwire the 240V or 208V - 4 wire service (L1, L2, N, & G) to the C-85 or C-95 control panel please refer to the panel's inner door label or the label printed in this manual.

Follow all local and national electrical codes for this installation and Consult a qualified electrician or service person if needed.

Hardwiring the Aerator:

The bottom of the C-85 and C-95 control panels have several knock-outs that can be removed to hardwire the unit. Remove a knock-out that will not be used for the main power. Install a strain relief fitting to secure the aerator's power cord, or you may need to install the power cord in a conduit if required. Consult your electrician.

For the C-95, use the terminal block near the bottom of the panel to hardwire the aerator. Refer to the C95 inner door label wiring diagram. The GREEN ground wire is attached to the left terminal, the WHITE wire is connected to the middle, and the BLACK wire is connected to the right terminal.

For the C-85, with the main power disconnected, connect the GREEN ground wire to the grounding strip at the bottom of the panel and secure tightly. Locate and remove the plastic shield on the yellow timer (black or clear depending on model). Under the shield, terminal #2 and #4 are LOAD terminals to supply power to the aerator. Loosen the screws and remove the existing wires that connect the external outlet on the side of the panel. Cap these wires off individually with wire nuts. This will disconnect the power from the outlet on the side of the panel. Insert the WHITE wire under the #2 terminal on the timer and the BLACK wire under the #4 terminal. Tighten both terminals securely. Replace the timer cover and the metal barrier plate in panel.

Test the GFCB with the test button now and every 30 days.

If lights are installed, they can now be installed per Instructions included with the lights.

Once completed, power can be restored to the panel. Enjoy your new kasco aerator!

MODEL: C85

DISPLAY AERATOR CONTROL WITH TIME SWITCH, GFCB, LIGHTNING ARRESTOR AND 15 AMP GFCI LIGHTING RECEPTACLE SUITABLE FOR USE WITH SUBMERSIBLE LIGHTS

IN RAINPROOF (TYPE 3R) ENCLOSURE SUITABLE FOR INDOOR OR OUTDOOR USE 40 AMP. MAX PER LEG 120/240 VOLT SINGLE PHASE (THREE WIRE) AC

PUMP CIRCUIT: 3 hp max, 240 Vac, LIGHT CIRCUIT: 120 Vac - 15 amp Max.

MIN 75° C SUPPLY CONDUCTORS

PHOTO CONTROL RATINGS: 120 VAC 50/60 HZ. 1800W TUNGSTEN, 8.3A BALLAST

LIGHTNING ARRESTOR RATINGS: 120/240 VAC; MCOV 250 VAC

Note: The short circuit current rating of this panel is 10,000 symmetrical amperes.



IMPORTANT: This control panel must be installed according to the National Electrical Code (including article 680) and local code requirements. The main lugs and neutral main are suitable for No. 14 to 2 AWG **COPPER** conductors. Follow gauge selection table and corresponding terminal screw tightening torque requirements below. An additional branch circuit protector (20 Amp max) may be installed in the unused position for use as an auxiliary circuit. Use only Square D HOM Series circuit breakers for addition or replacement (do not exceed ratings on wiring diagram). Follow Manufacturers instructions for testing of ground fault circuit breakers (GFCB). This panel is equipped with a 120V AC - 15 amp duplex GFCI receptacle for connecting a 120V AC light kit or an external low voltage transformer for lighting. The receptacle power is controlled by the timer-photoelectric circuit. Refer to the instructions provided with your light kit. After wiring, install front panel over wiring compartment.

Wiring information-Copper Conductors	
Wire Size	Terminal Tightening Torque
AWG	Lb-In
14	20
12	20
10	20
8	25
6	35
4	45
3	50
2	50

KEEP DOOR CLOSED AT ALL TIMES.

TIME SWITCH OPERATING INSTRUCTIONS

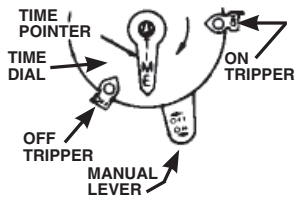

1. TO SET "ON" AND "OFF" TIMES:

Hold TRIPPERS against edge of CLOCK-DIAL, pointing to time (AM or PM) when **ON** and **OFF** operations are desired. Tighten tripper screws firmly.

2. TO SET TIME-OF-DAY:

Pull CLOCK-DIAL outward. Turn in either direction and align the exact time-of-day on the CLOCK-DIAL (the time now, when switch is being put into operation) to the pointer.

-DO NOT MOVE POINTER-

- **TO OPERATE SWITCH MANUALLY:** Move MANUAL-LEVER below left or right as indicated by arrows. This will not affect the next operation.

- **FOR MORE THAN ONE DAILY ON-OFF OPERATION:** Place additional tripper pairs on CLOCK-DIAL (order 156T1978A).

- **IN CASE OF POWER FAILURE:** Reset CLOCK-DIAL to proper time of day. See step 2 above.

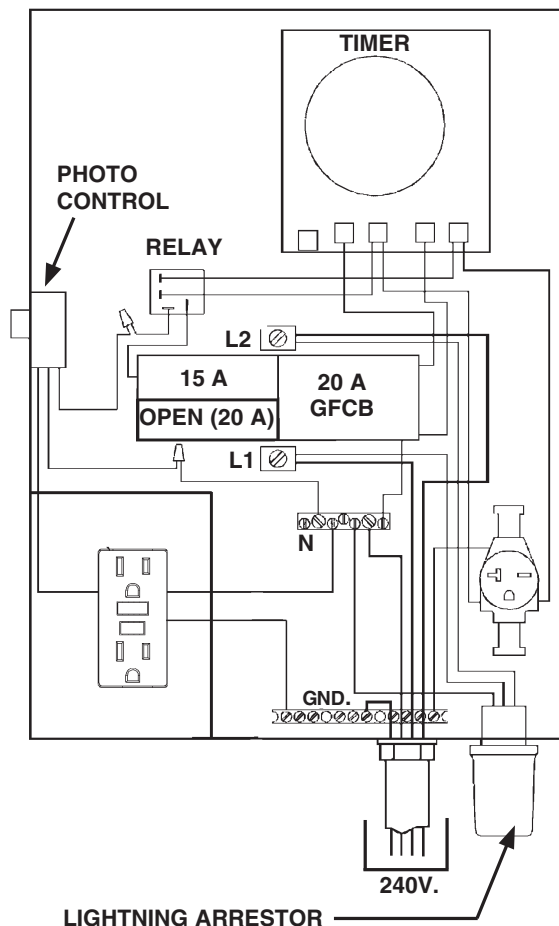

KASCO MARINE, INC.,
800 Deere Road
Prescott, WI 54021-1241
• Phone (715) 262-4488

158PS13244

MODEL: C95

DISPLAY AERATOR CONTROL WITH TIME SWITCH, GFCB,
LIGHTNING ARRESTOR AND 15 AMP GFCI LIGHTING RECEPTACLE
SUITABLE FOR USE WITH SUBMERSIBLE LIGHTS

IN RAINPROOF (TYPE 3R) ENCLOSURE SUITABLE FOR INDOOR OR OUTDOOR USE
40 AMP. MAX PER LEG 120/240 VOLT SINGLE PHASE (THREE WIRE) AC
PUMP CIRCUIT: 24 FLA, 144 LRA, 240 Vac, LIGHT CIRCUIT: 120 Vac - 15 amp Max.
MIN. 75° C SUPPLY CONDUCTORS

PHOTO CONTROL RATINGS: 120 VAC 50/60 HZ. 1800W TUNGSTEN, 8.3A BALLAST
LIGHTNING ARRESTOR RATINGS: 120/240 VAC; MCOV 250 VAC



IMPORTANT: This control panel must be installed according to the National Electrical Code (including article 680) and local code requirements. The main lugs and neutral main are suitable for No. 14 to 2 AWG **COPPER** conductors. Follow gauge selection table and corresponding terminal screw tightening torque requirements below. An additional branch circuit protector (20 Amp max) may be installed in the unused position for use as an auxiliary circuit. Use only Square D HOM Series circuit breakers for addition or replacement (do not exceed ratings on wiring diagram). Follow Manufacturers instructions for testing of ground fault circuit breakers (GFCB). This panel is equipped with a 120V AC - 15 amp duplex GFCI receptacle for connecting a 120V AC light kit or an external low voltage transformer for lighting. The Pump Terminal Bar is controlled by the timer only. The Lighting GFCI outlet is controlled by the timer and photoelectric circuit. Refer to the instructions provided with your light kit. After wiring, install front panel over wiring compartment.

KEEP DOOR CLOSED AT ALL TIMES.

Wiring information-Copper Conductors	
Wire Size	Terminal Tightening Torque
AWG	Lb-In
14	20
12	20
10	20
8	25
6	35
4	45
3	50
2	50

TIME SWITCH OPERATING INSTRUCTIONS

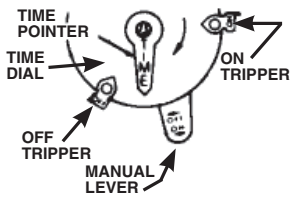

1. TO SET "ON" AND "OFF" TIMES:

Hold TRIPPERS against edge of CLOCK-DIAL, pointing to time (AM or PM) when **ON** and **OFF** operations are desired. Tighten tripper screws firmly.

2. TO SET TIME-OF-DAY:

Pull CLOCK-DIAL outward. Turn in either direction and align the exact time-of-day on the CLOCK-DIAL (the time now, when switch is being put into operation) to the pointer.

-DO NOT MOVE POINTER-

- **TO OPERATE SWITCH MANUALLY:** Move MANUAL-LEVER below left or right as indicated by arrows. This will not affect the next operation.
- **FOR MORE THAN ONE DAILY ON-OFF OPERATION:** Place additional tripper pairs on CLOCK-DIAL (order 156T1978A).
- **IN CASE OF POWER FAILURE:** Reset CLOCK-DIAL to proper time of day. See step 2 above.

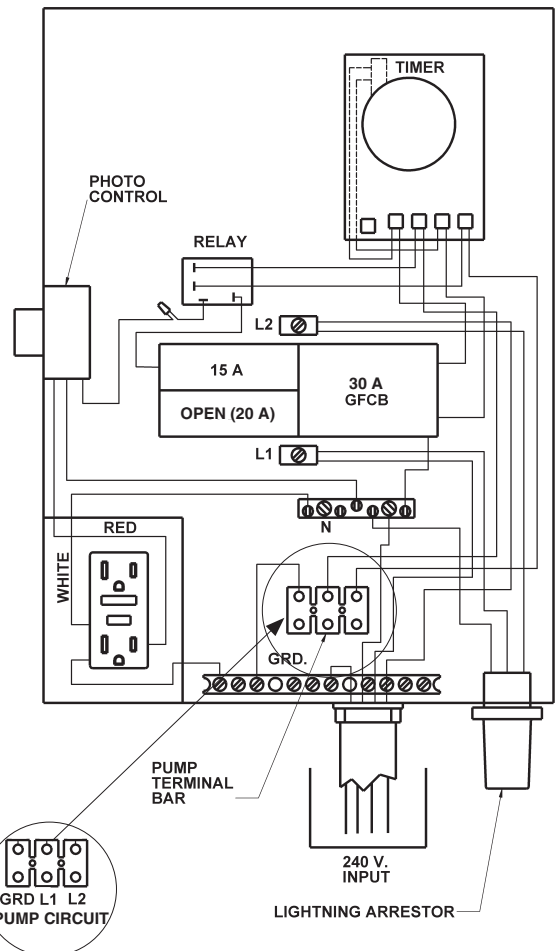

KASCO MARINE, INC.,

800 Deere Road
Prescott, WI 54021-1241

• Phone (715) 262-4488

158PS13206

3 Phase Startup Procedure

If a Kasco Control Panel is not provided, please refer to the following warnings:

When inherent overheating protection is not provided: use with approved motor control that matches motor input in full load amperes with overload element(s) selected or adjusted in accordance with control instructions.

Utiliser un démarreur approuvé convenant au courant à pleine charge du moteur et dont les éléments thermiques sont réglés ou choisis conformément aux instructions qui l'accompagnent.

When inherent overheating protection is provided: use with approved motor control that matches motor input in full load amperes. See table below.

Utiliser un démarreur approuvé convenant au courant à pleine charge du moteur.

Note: The motor input in full load amperes is the marked value or the service factor amperes, shown on the nameplate.

3 phase 208- 230 Volt	2.3JF	3.3JF	5.3JF	7.3JF
Full load amps	7.5	10.3	16.0	20.0

3 phase 460 Volt	2.3HJF	3.3HJF	5.3HJF	7.3HJF
Full load amps	3.6	5.1	7.8	10.0

Control panels must be installed by a qualified electrician.

If unit is connected to a circuit protected by a fuse, use a time-delay fuse with this pump.

You must verify motor rotation before installing the unit in the water.

3phase Kasco units will run in a clockwise rotation when looking down at the impeller. On J series units the upper pump housing must be removed to see the impeller. Stand clear of the impeller while verifying rotation. If a Kasco 3 phase panel is supplied, follow the instructions with the panel. Also follow the steps below.

Electrician:

1. Verify all screw terminal connections are tightened to specified torque setting prior to energizing the panel.
2. Verify the electrical service (voltage and Phase) matches the control panel and aerator nameplates ratings. Refer to the control panel instructions and schematics for installation details.
3. Verify all switches, circuit breakers, and motor starters are in the OFF position
4. Connect electrical service to this control panel as shown in the electrical schematic that came with the panel.
5. Connect the unit power cord to this panel as shown in the electrical schematic.
6. Set the motor starter overload to the FLA rating on the aerator nameplate.
7. Pump rotation: Remove the upper pump housing (if you have a J series aerator) by removing the three screws attaching it to the lower pump housing. The pump rotation is clockwise when looking down at the impeller. Apply power to the control panel. Turn on the 15amp control circuit breaker, and motor starter.
8. Momentarily turn the Hand-Off-Auto switch to Hand. This will run the aerator. Do not run the aerator for more than a few seconds on shore. If the rotation is not correct. Disconnect and lock out power from the control panel. Swap any two of the aerator power cord wires in the panel. This will cause the motor to reverse direction. Reapply power to the panel and verify the rotation is clockwise.
9. Once rotation is verified, with the power disconnected and locked out again, reinstall the upper pump housing. Run the aerator one more time momentarily on shore to ensure the housing was reinstalled correctly. Disconnect and lock out power again and continue with installation of the aerator as detailed in the aerator owner's manual.

Record the following data while the unit is operating in the water under load:

Voltage:	Amperage:
L1-L2 _____	L1 _____
L1-L3 _____	L2 _____
L2-L3 _____	L3 _____

Current unbalance should not exceed 5% at full load

3 Phase Control Panel Timer

TIME CLOCK SETTING

TO SET THE CURRENT TIME, TURN THE MINUTE HAND CLOCKWISE. DO NOT SET THE TIME BY ROTATING “OUTER” DIAL.

Turn the minute hand clockwise until the time of day on the outer dial is aligned with the triangle marker on the inner dial (two o'clock position).

Example for 10:00 AM. Turn the minute hand clockwise until 10:00 AM is aligned with the triangle on the inner dial. The hour and the minute dial will show exactly 10:00.

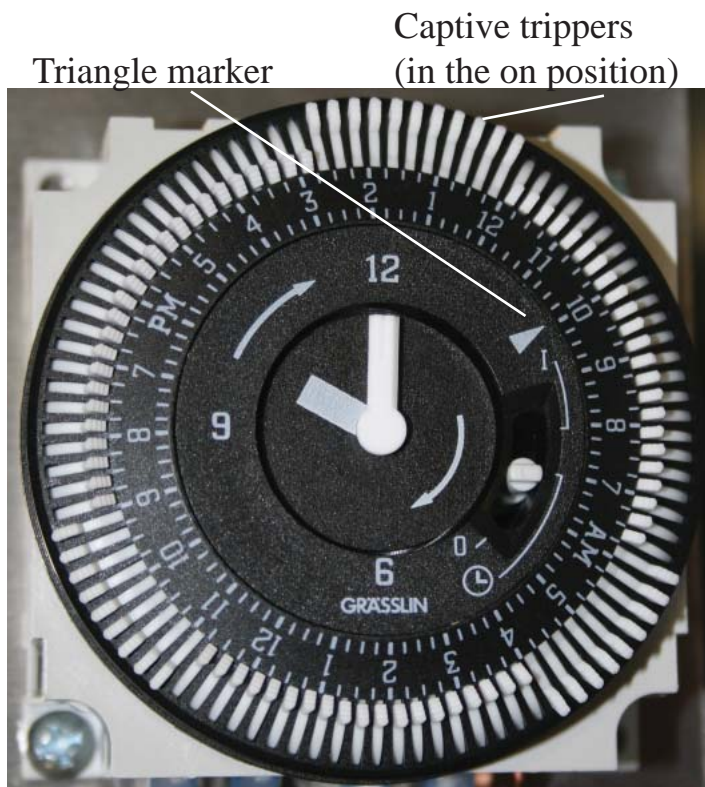

PROGRAMMING

The 24-Hour dial has quarter-hour divisions and AM/PM indications.

The time switch is programmed by pushing the captive trippers to the outer ring position for the entire period that the aerator is to be turned “ON”, i.e., fifteen minutes for each tripper on the 24-Hour dial. When the tripper is pushed to the inside, the switch is in the “OFF” position.

PROGRAMMING WITH MANUAL OVERRIDE SWITCH

AUTOMATIC MODE

In order to operate the time clock in the automatic mode, the manual switch must be in the center position (automatic) - see diagram.

MANUAL MODE

With the manual override switch in the lower position, marked “O”, the time clock output will remain Permanently OFF. In the upper position, marked “I”, the time clock output will remain permanently ON

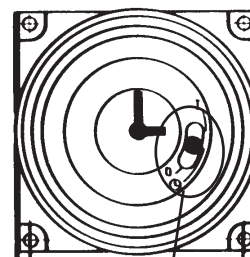

Override Mode	
3-way manual override switch	I = permanent ON ⊕ = automatic O = permanent OFF

8400JF, 2.3JF Replacement Parts

ITEM NO.	PART NO.	DESCRIPTION	QTY.
1	840250	JET PUMP HOUSING	1
2	840260	IMPELLER, 8400	1
3	840240	2 HP HOUSING CONE	1
4	840220	8400 JET/ PUMP BASE	1
5	475628	SCREW, FILLISTER HEAD	3
6	990275	O RING, CORD	1
7	990280	SEALING PLUG	1
8	990281	O RING	1
9	475625	SCREW, 10-24 X 2.5" LONG	3
10	475626	FLAT WASHER, #10	3
11	475642	WASHER, 1/2"	2
12	993201	WIRE CAGE ASSEMBLY	1
13	261231	5/16 FLAT WASHER	2
14	261234	NUT, HEX	1
15	261240	5/16-18X1 1/4 HHCS	1
16	689146	HOLD DOWN BRACKET	3
17	258476	FLAT WASHER, 1/4"	3
18	584692	1/4-20 X 1-3/8" BOLT	3
19	840475	ZINC ASSEMBLY	1

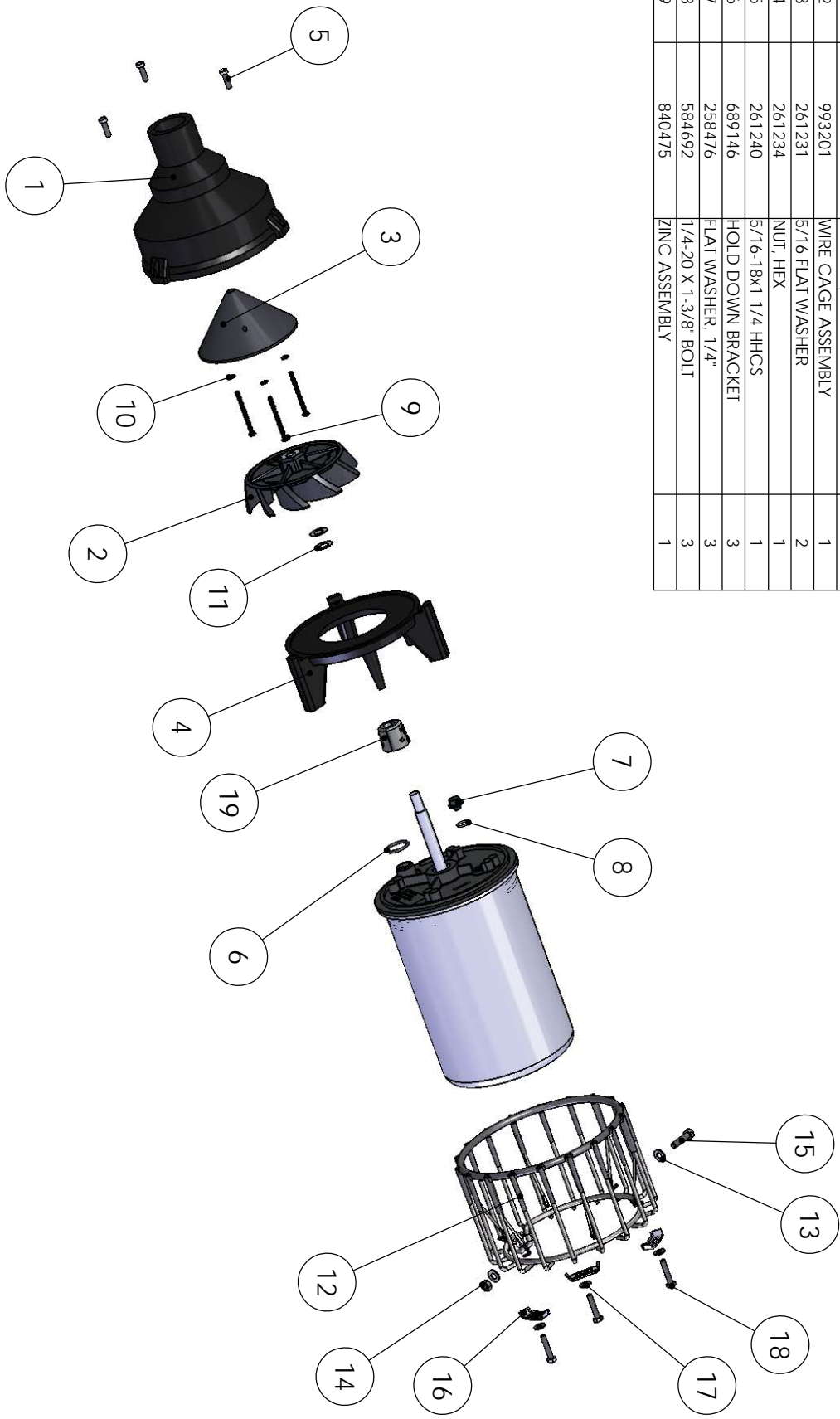

3.1JF, 3.3JF Replacement Parts

ITEM NO.	PART NO.	DESCRIPTION	HP/LQTY.
1	840250	JET PUMP HOUSING	1
2	840360	IMPELLER, 3 HP	1
3	840240	2 HP HOUSING CONE	1
4	840220	8400 JET/ PUMP BASE	1
5	475628	SCREW, FILLISTER HEAD	3
6	990275	O RING, CORN	1
7	990280	SEALING PLUG	1
8	990281	O RING	1
9	475625	SCREW, 10-24 X 2.5" LONG	3
10	475626	FLAT WASHER, #10	3
11	475642	WASHER, 1/2"	1
12	993201	WIRE CAGE ASSEMBLY	1
13	261231	5/16 FLAT WASHER	2
14	261234	NUT, HEX	1
15	261240	5/16-18x1 1/4 HHCS	1
16	689146	HOLD DOWN BRACKET	3
17	258476	FLAT WASHER, 1/4"	3
18	584692	1/4-20 X 1-3/8" BOLT	3
19	840475	ZINC ASSEMBLY	1

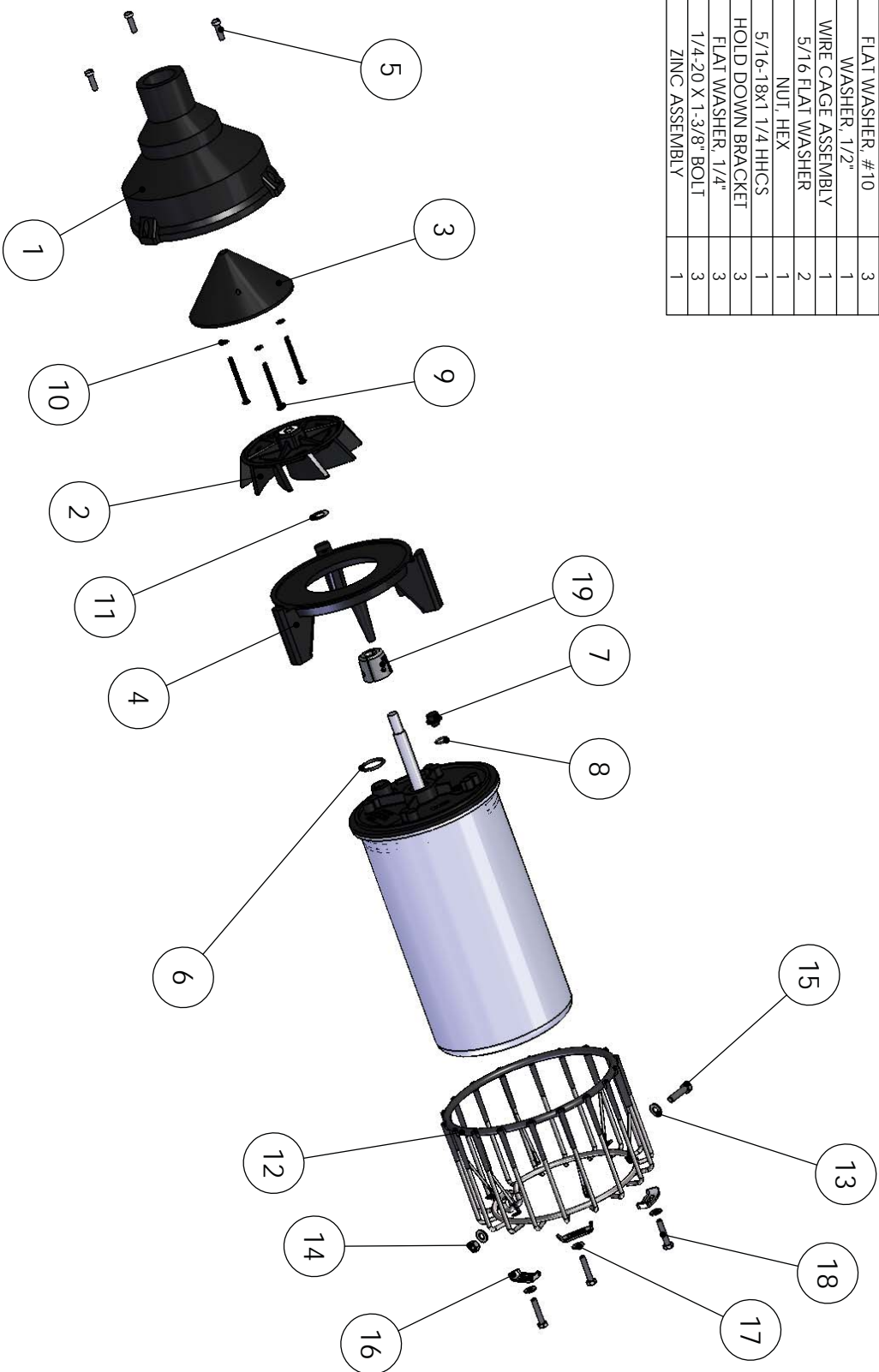

5.1JF, 5.3JF Replacement Parts

ITEM NO.	PART NO.	DESCRIPTION	QTY.
1	840550	5.1 J HOUSING	1
2	840560	IMPELLER, 5 HP	1
3	840558	CONE, 5.1J	1
4	840220	8400 JET/ PUMP BASE	1
5	820700	ASSEMBLY, BLACK TOP, 8400	1
6	475628	SCREW, FILLISTER HEAD	3
7	990290	O RING	1
8	995100	CAN, 5 HP FOUNTAIN	1
9	990280	SEALING PLUG	1
10	990281	O RING	1
11	475625	SCREW, 10-24 X 2.5" LONG	3
12	475626	FLAT WASHER, #10	3
13	475642	WASHER, 1/2"	1
14	993201	WIRE CAGE ASSEMBLY	1
15	261231	5/16 FLAT WASHER	2
16	261234	NUT, HEX	1
17	261240	5/16-18X1 1/4 HHCS	1
18	689146	HOLD DOWN BRACKET	3
19	258476	FLAT WASHER, 1/4"	3
20	584692	1/4-20 X 1-3/8" BOLT	3
21	840475	ZINC ASSEMBLY	1

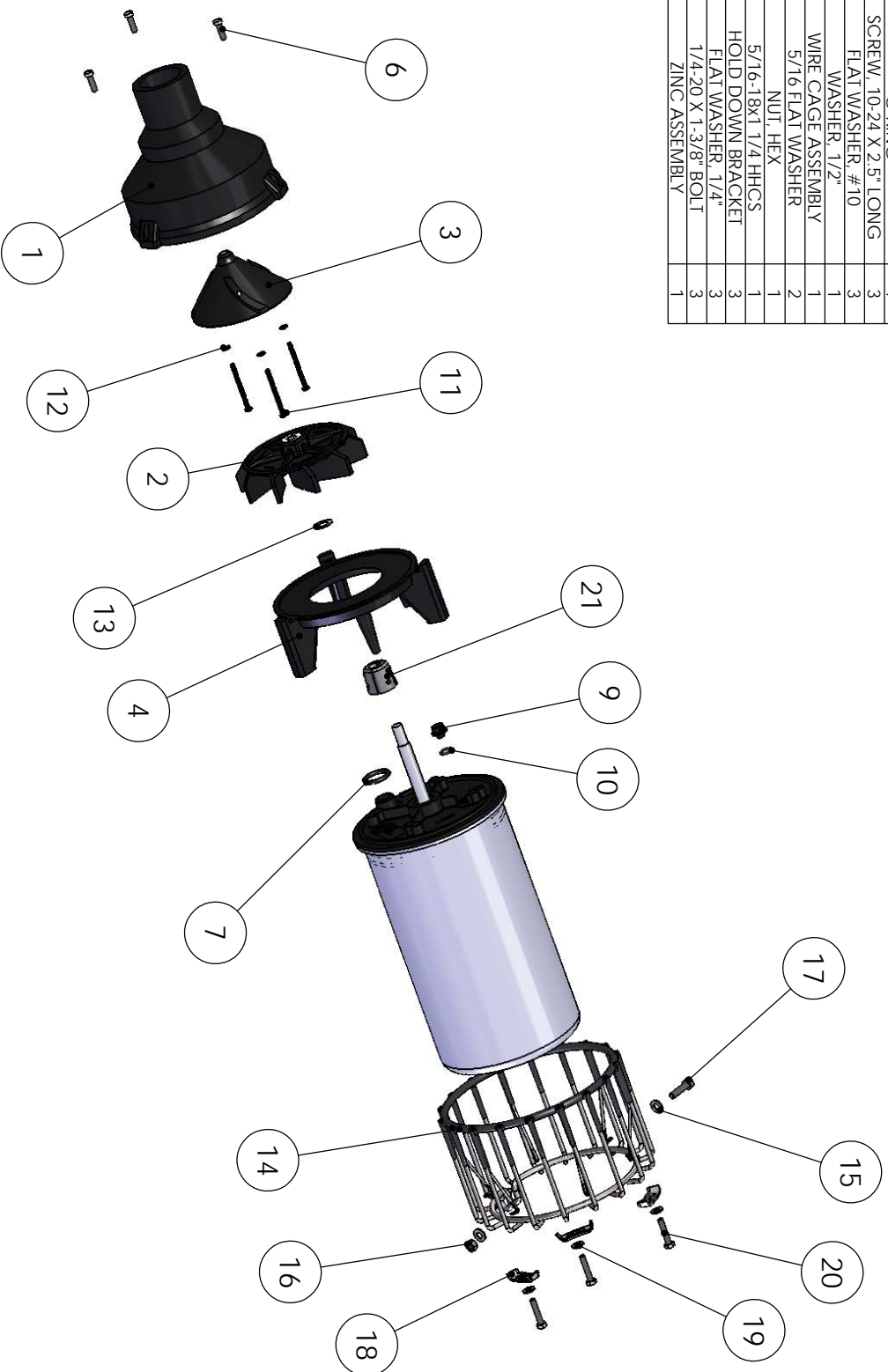

7.3JF Replacement Parts

ITEM NO.	PART NO.	DESCRIPTION	QTY.
1	475628	SCREW, FILLISTER HEAD	3
2	702200	UPPER HOUSING, 7 HP	1
3	840240	2 HP HOUSING CONE	1
4	475626	FLAT WASHER, #10	3
5	475625	SCREW, 10-24 X 2.5" LONG	3
6	702100	IMPELLER, 7.5 HP	1
7	475642	WASHER, 1/2"	1
8	840475	ZINC ASSEMBLY	1
9	702300	PUMP BASE, 7 HP	1
10	990290	O RING	1
11	990280	SEALING PLUG	1
12	990281	O RING	1
13	140312	RETAINING CLIP	1
14	840537	LOCK WASHER, 1/4"	6
15	451130	1/4-20 X 1" HEX HEAD CAPSCREW	6

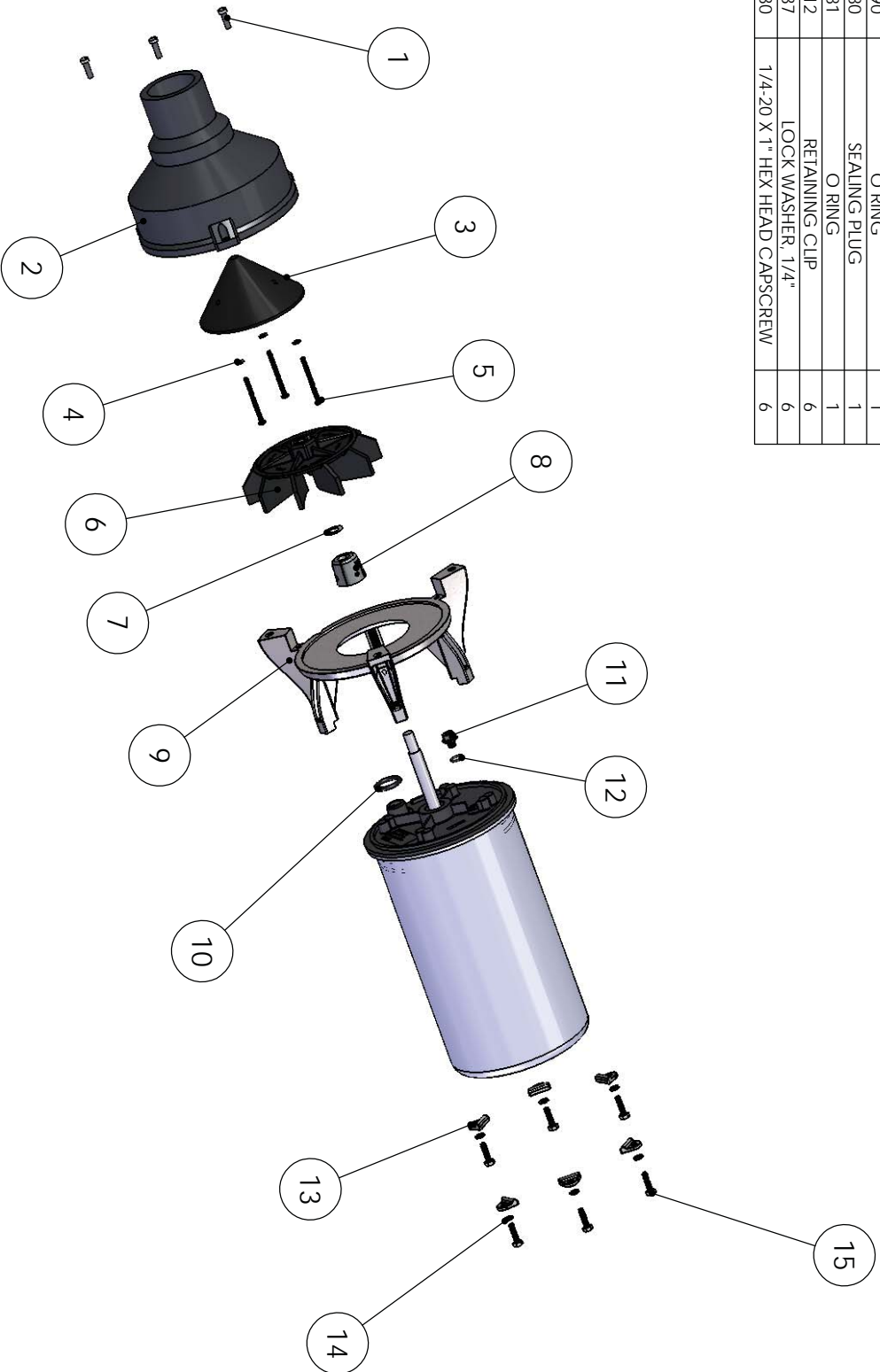

Maintenance Recommendations

**** Under No Circumstances should anyone enter the water while a aerator is operating. ****

**** Please keep the original box for maintenance shipping. ****

The following maintenance procedures can be utilized to ensure many years of quality performance from your Kasco aerator and reduce the need for more costly repair work.

PROPER INSTALLATION: Proper installation of Kasco equipment will include a power source with ground fault interruption. For aerator models, the C-85 or C-95 (240/208V) included with the unit have built-in ground fault interruption that is sufficient. Ground fault interrupters are a safety feature that can also alert you to electrical leaks in the equipment. It is extremely important to test the GFI upon installation, each reinstallation, and monthly thereafter to ensure proper operation. If you have repeat, consistent trips on your ground fault, the equipment should be disconnected and removed from the water. The power cord should be inspected for damage and you should call Kasco Marine at 715-262-4488 for further instructions or email Kasco at service@kascomarine.com.

OBSERVATION: Operating equipment should be observed on a regular basis (daily, if possible) for any reduction or variation in performance. If a change in performance is observed, the equipment should be disconnected from power and inspected for any material that may have clogged the system or wrapped around the shaft of the motor, especially plastic bags and fishing line. Even though Kasco Aerators are among the most clog-resistant on the market, it is impossible to protect against all items that can clog equipment and still maintain a flow of water. These materials can be very damaging to the equipment under continued operation and must be removed as soon as possible. **ALWAYS UNPLUG THE UNIT BEFORE ATTEMPTING TO REMOVE CLOGS.**

WINTER STORAGE: In regions where there is significant freezing in the wintertime, the aerators should be removed from the water to protect them from the expansion pressure of the ice. In many areas, aerators will keep some amount of ice open through the winter. However, when the water is thrust into the air, it is

exposed to the colder air temperatures longer and can actually make ice thicker on the pond/lake. Storage over winter is best in a location that is out of the sun and cool, but above 32°F. It is not necessary to store Kasco motors upside down.

CLEANING: Aerators should be removed from the water at least once per year (at the end of the season in cold climates) to clean the exterior of the system, especially the stainless steel motor housing (can). The motor housing is the surface that dissipates heat into the water and any algae, calcium, etc. build-up will become an insulator that blocks heat transfer. In warmer regions it is recommended that the motor is removed and cleaned at least two to three times per year depending on conditions. In most cases a power washer will be sufficient if the unit and algae are still wet.

SEAL AND OIL REPLACEMENT: This is a sealed motor assembly and seals will wear out over time (similar to brake pads on a car). Replacement of the seals and a change of oil after three years may add longevity to the operation of the motor, saving you the cost of more expensive repairs. In warmer climates where the aerator runs most or all of the year, it is a good idea to replace seals more regularly than you would need to in colder climates where the unit is removed from the water for several months.

ZINC ANODE: A Sacrificial Zinc Anode is supplied on the shaft of all 8400JF, 3.1JF, and 5.1JF Model aerators for protection of the equipment from corrosion and electrolysis. The zinc anode should be updated (replaced) if reduced to half the original size or if white in color. Corrosion from electrolysis is more commonly associated with saltwater or brackish water, but as a matter of precaution, it is important to periodically check the zinc anode in all installations (at least every two to three months).

Seal replacement and all other repair services should be performed by Kasco Marine or a Kasco trained Authorized Repair Center. Any alterations or changes made to Kasco units by an unauthorized source will void the warranty. This includes tampering with the unit, power cord, and/or control box. Please contact Kasco Marine, Inc. at 715-262-4488 for your nearest Authorized Repair Center.

Warranty Policy

3 Year Limited Warranty: Kasco® Marine, Inc. warrants this aerator to be free from defects in material or workmanship (except for the ropes, power cord, and propeller) under normal use and service. The Kasco Marine, Inc. obligation under this warranty is limited to replacing or repairing free of charge any defective part within three (3) years from the date of shipment. Customer shall pay shipping charges for returning the unit to Kasco or an Authorized Repair Center.

THIS WARRANTY IS IN LIEU OF ANY OTHER WARRANTIES, EXPRESSED OR IMPLIED, AND ANY OTHER OBLIGATION OR LIABILITY WHATEVER ON THE PART OF KASCO MARINE, INC. AND IN NO EVENT SHALL KASCO MARINE, INC. BE LIABLE FOR ANY SPECIAL OR CONSEQUENTIAL DAMAGES.

Warranty is void if:

- The aerator is not maintained properly according to the Maintenance Recommendations supplied in this Owners Manual.
- The aerator is returned for repair without the power cord or if the unit, control box, or power cord are altered in any way from original shipment. Cuts in the power cord are not covered under warranty.
- The aerator is not used with the supplied GFI control box.
- The aerator is damaged by unauthorized tampering.
- The Sacrificial Zinc Anode around the propeller shaft shows significant deterioration. (The Anode must be inspected periodically and replaced if necessary.)

Warranty Claim Procedure:

The best method for establishing warranty period is by the original receipt. Also, register the aerator online at: www.kascomarine.com (Under the technical tab)

Once the warranty coverage has been established, the unit may be sent to any Kasco Authorized Repair Center for evaluation and repair. Please call Kasco Marine at 715-262-4488 prior to shipping to receive any updated information and/or Repair Form, then ship to:

Kasco Marine, Inc.
800 Deere Rd.
Prescott, WI 54021
Attn: Repairs

Or call Kasco Marine at 715-262-4488 to locate your nearest Authorized Repair Center. You can also email Kasco at service@kascomarine.com.

Note: Only complete motor assemblies will be accepted for warranty repair. The power cord and all other components must be returned with the motor as originally assembled. Any missing parts will be replaced at the customer's expense and, if determined to have caused the failure, could void the entire warranty. Some parts are essential for structural support during shipping and others, such as the power cord, are essential to properly diagnose potential causes of failure. It is not necessary to return the control box, float, or nozzles with the motor assembly, unless specifically asked to by a Kasco representative.

Please include the Repair Form received from Kasco Marine or your local distributor with the shipment. If no Repair Form is available, include your name and physical address for return delivery of the repaired unit and a daytime phone number and/or e-mail address for correspondence regarding the warranty claim.

Any expedited shipping method for the return of the unit is at the customer's expense. Kasco Marine will return units repaired under warranty at our expense via ground freight within the continental United States.

Other Repairs:

Most failed equipment can be repaired at substantially lower costs than replacement with new. Please ship according to the instructions in the previous section. Again, it is best to call ahead for updated information and/or Repair Form.

Kasco Marine does estimates on repairs at the request of the customer. The request for estimate should be included in the letter that accompanies the returned unit and must include a daytime phone number and/or e-mail address. Estimate options are as follows:

We will contact the customer with a total after the unit has been evaluated, but before the work is performed. We will repair the unit only if repair costs are under a stated dollar amount. Example: "Please repair if total

is under \$150.00 before shipping charges.”

All estimates that are rejected for repair will be destroyed unless otherwise directed by the customer. If the customer would like the unit returned, the unit will be restored as closely as possible to the condition in which it was received and shipped at the customer’s expense for shipping and handling charges.

Billing:

All non-warranty repairs will be returned to the customer and billed C.O.D. unless otherwise directed. Kasco Marine also accepts Visa and MasterCard credit card payments. Kasco Marine will call for credit card information upon completion of the repair at the customer’s request.

All other warranty and repair inquiries should be directed to Kasco Marine, Inc. at 715-262-4488 or returns@kascomarine.com.

Troubleshooting Tips

Below are some helpful troubleshooting tips. If a problem occurs, please double check the assembly and installation instructions as well as the instructions for the proper control panel. More troubleshooting tips can be found at www.kascomarine.com (Under the Technical tab)

“My Aerator trips the ground fault interrupter in the Control Panel.”

This is the most common symptom of several possible problems. To correctly diagnose the problem, you will need to collect more information. A Ground Fault Interrupter (GFI) breaker that trips can indicate an electrical service problem, water contamination in the unit and/or cord, bad breaker, control box problems, motor problems, etc. Try to find out the answers to these questions before you contact Kasco to narrow down the problem.

- How long does it take to trip the breaker?
- Does it always take the same amount of time to trip?
- How many times has it tripped?
- Has there been any electrical problems in the area recently?

“My Aerator seems to run slowly.”

This can also be a symptom of several possible problems. There could be an electrical problem where the unit is not getting the proper voltage. This could also indicate a problem with the motor of the unit, which needs to be looked at by an Authorized Repair Center. Check that the unit is receiving the proper voltage, and, if so, contact Kasco for further steps.

“My Aerator hums, but will not start. When I spin the prop with a stick, it starts up.” (single phase units only)

This indicated a problem with the Starting Capacitor. Each Kasco single phase aerator is equipped with a Starting Capacitor to get the unit going when it is first plugged in. If it is operating, but not spinning and can be started by spinning the prop with a stick, the Starting capacitor needs to be replaced by an Authorized Repair Center.

“My Aerator turns itself off and back on without the timer and without tripping the GFI breaker.” (single phase units only)

Each Kasco single phase aerator has a Thermal Overload built in that will turn the unit off when it overheats. Once the unit has cooled down, it will start back up. If you are noticing these symptoms, the unit should be unplugged immediately because the Thermal Overload will continue to turn on and off until it burns out and damages the motor. The unit should be unplugged and taken out of the water to find the cause of the problem. The problem could be one of many, such as, low water levels, build-up on the unit to prevent heat dissipation, something inhibiting the free rotation of the shaft, etc. If something is caught in the unit or there is a build-up on the unit, remove the debris and, if caught early enough, the unit should be fine. Contact a Kasco representative before restarting the unit.

“My Aerator flow seems to fluctuate and/or be less than usual.”

This can occur because of a few different reasons. Most of the time, this symptom is caused from unit being clogged with debris. A mat of weeds, many leaves, plastic bags, etc. can clog up the unit and cause it to be starved of water. If the unit does not have the proper amount of water, the flow or pattern will fluctuate up and down and look sporadic. If you are seeing these symptoms, unplug the unit and clean away the debris that is clogging up the screen. Another possibility if these symptoms are noticed, is a chipped or damaged prop that is causing the unit to wobble and not pump properly. When the unit is unplugged, check the prop for damages and replace if damage is found.

“The GFI breaker trips randomly and sporadically. Sometimes it is a few hours of operation, other times it can be days or weeks.”

This is referred to as a Nuisance Trip. This usually occurs where the unit is installed a great distance from the initial electric service on the property where the ground stake is placed. It is caused by either induced current in the ground wire or a base voltage difference due to soil pH levels. A possible resolution to the problem, contact an electrician and install a local grounding stake. This may eliminate the induced current and any base voltage differences.



800 Deere Rd.
 Prescott, WI 54021
 Phone: 715-262-4488 - Fax: 715-262-4487
 www.KascoMarine.com Sales@KascoMarine.com

Customer Repair Form

*** Important Reminders ***

- All repairs sent in **MUST** be accompanied by a copy of this completed sheet!
- Routine maintenance consists of checking the zinc anode regularly and replacing if necessary, keeping the unit clean, keeping the stainless steel can clean, and having the seals and oil replaced every 3 years depending on use.
- Address your Repair to Kasco Marine, Attn: Repairs (or to your Authorized Repair Center).
- Shipping to Kasco or an Authorized Repair Center is paid for by the customer.
- You must include the power cord and cage assembly with each unit sent in for repair to be considered for warranty repair!
- Do not ship the float and/or control box with the unit for repair, unless otherwise instructed.

Today's Date: _____

Customer Information

Name: _____

Phone Number: _____

Address: _____

Alternate Number: _____

City: _____

Email Address: _____

State: _____

Zip Code: _____

Unit Information:

Model # (Ex. 8400JF): _____

Serial # (Ex. 9001J84025): _____

Date Purchased: _____

Purchased From: _____

Earliest Date of Problem: _____

Description of Problem:

Comments:

Registration Information

Please register your aerator online at:

www.kascomarine.com (Under the Technical Tab)

Also fill in the information below and keep for your records.

Model # (Ex. 3.1JF) _____

Serial # (Ex. 8001J311725) _____

Purchase Date: _____

Purchased From: _____

Registration Date: _____



Kasco Marine, Inc.
800 Deere Rd.
Prescott, WI 54021

Phone (715) 262-4488 * Fax (715) 262-4487

www.kascomarine.com * sales@kascomarine.com * service@kascomarine.com